

Shanghai Cixi Instrument Co.,Ltd





CATALOGUE

1. Company profile.....	3
2. Working principle and structure.....	3
3. Features.....	4
4. product structure:	4
5. Flowmeter wiring.....	5
5.1 Figure 1.....	5
5.2 Figure 2.....	5
5.3 Figure 3.....	6
6. Installation instructions (the cover must be vertical).....	6
7. M series oval gear flowmeter.....	7
7.1. M series Parameter.....	7
7.2. dimension figure (MM).....	8
8. G round gear flow meter.....	10
8.1G series Parameter.....	10
8.2. dimension figure (MM).....	11
9. P series Plastic gear flow meter.....	15
9.1 P series Parameter.....	15
9.2 PS series Parameter.....	15
9.2. dimension figure (MM).....	16
10. Selection list.....	17
11. Application industry.....	18
11.1 Application industry illustrate.....	19
12. Troubleshooting guide.....	20
13. Precautions for use:.....	21
14. Warranty date.....	21

1. Company profile

Founded in 2008, Shanghai Jishen Instrument Co., Ltd. was founded by former Siemens engineer Mr Stone. It specializes in R&D and production of high quality, high precision, high frequency, high temperature, high pressure and wide range flowmeters. The production line strictly implements ISO9001 standard. Using the patented technology developed by ourselves, it replaces the blank of China's micro-gear flowmeter, and also produces automatic control instruments for gear pump and vacuum measurement, micro-liquid quality control, and micro gas quality control.

The products can completely replace Max, KRACHT, OVAL and other international brands. The products meet the needs of most markets, including water, oil, food, lubricants, chemicals, cosmetics, fertilizers, inks, pharmaceuticals, coatings, petroleum, Automotive, glue, polyurethane, electrolytes and additives all could be measurabled.

2. Working principle and structure

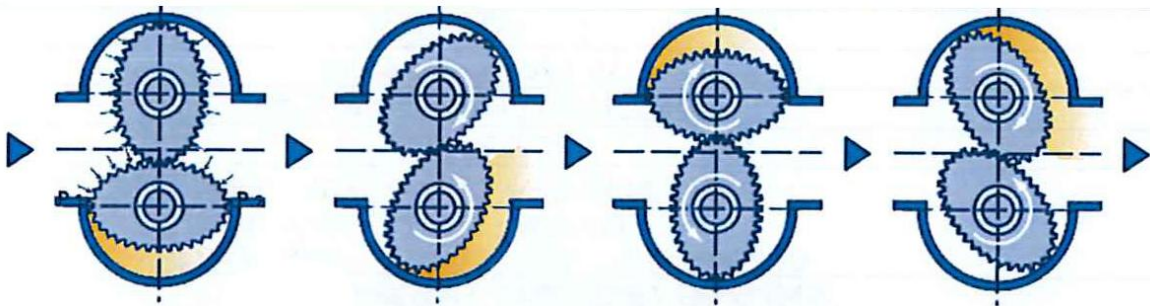

The flowmeter cavity has a pair of intermeshing gears as the rotor, and the two gears and the cavity respectively form a fixed volume, which is called a standard volume. Gear flow is measured by counting the number of standard volumes that flow through a given period of time.

The spur gear flowmeter is a new type of volumetric flowmeter, also called Fuda flowmeter, which is used for precise continuous or intermittent measurement of the flow rate or instantaneous flow of liquid in pipelines. It is suitable for viscosity of heavy oil, polyvinyl alcohol and resin. High media flow measurement.

3. Features

- The larger the viscosity of the medium, the smaller the leakage amount from the gear and the metering gap. Therefore, the larger the viscosity of the measured medium, the smaller the leakage error, and the better the measurement.
- Small volume, light weight, low vibration and noise during operation, high viscosity fluid can be measured. The measurement accuracy is 0.5 level and 0.2 level. Measuring range up to 100:1
- It has a variety of general-purpose, high-pressure type, food type, etc. It is suitable for small flow measurement of various cleaning liquids.
- No straight pipe is required.
- Suitable for pulsating fluid measurements.
- can be used for micro-short-time quantitative addition

4. product structure:

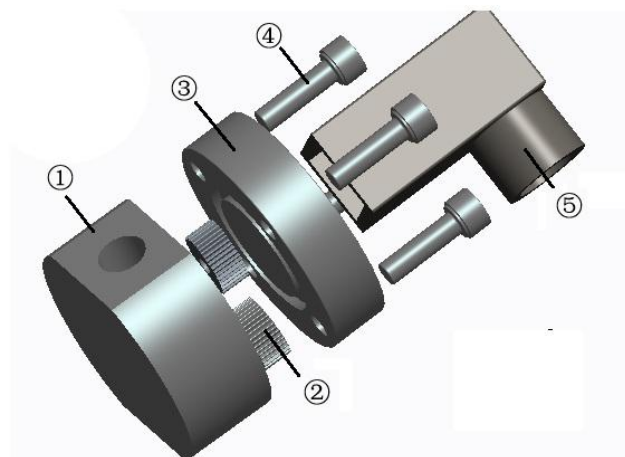

- ① Gear cavity plate
- ② Gear
- ③ Cover plate
- ④ Fixed thread
- ⑤ Hesman connector

5. Flowmeter wiring

Note: Before installation, please read this part carefully, and make sure you really understand the meaning.

1. Before connecting to the pipeline, be sure to connect the circuit to test whether the signal matches properly (the gear can be rotated by hand or by blowing the flowmeter through the mouth to check the pulse signal).
2. See the wiring diagram of the circuit (see Figure 1).
3. Before the flowmeter is connected to the pipeline, it is necessary to ensure that the pipeline is clean. It is better to wash the pipeline first. It is recommended to install a filter of 200 mesh or more on the front end of the flowmeter.

5.1 Figure 1

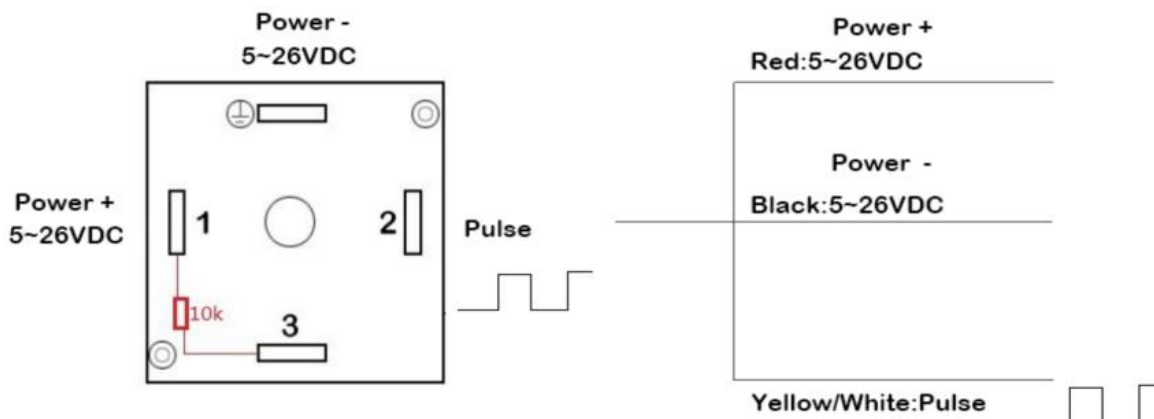

5.2 Figure 2

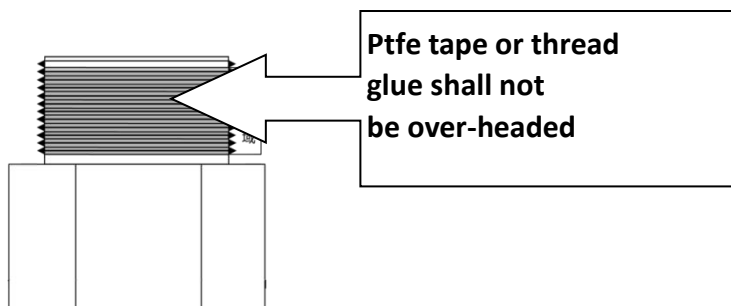

5.3 Figure 3

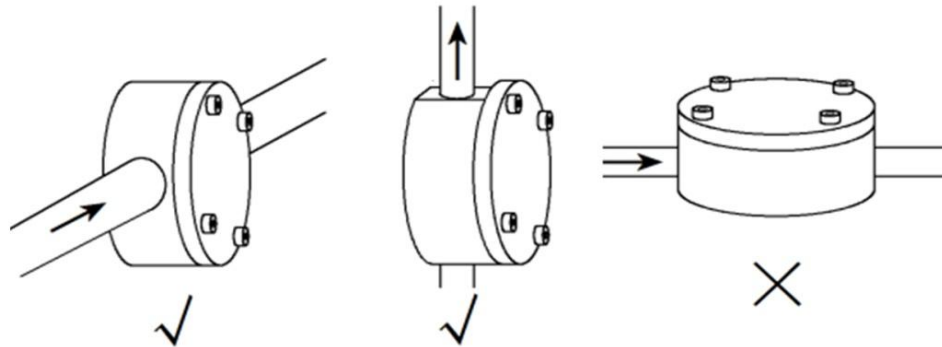

Note: G-series flow meter with ball bearings have no requirement of installation direction.

6. Installation instructions (the cover must be vertical)

- a. Pipeline cleaning requirements: Thoroughly clean the pipe before installation and install a filter in front of the flowmeter (recommended 200 mesh or more) to prevent debris from entering the flowmeter. During the installation process, be sure to avoid dirt and impurities from entering the flow inlet end. Pay attention to the joint raw material belt.(Figure 2)
- b. Installation direction requirements: It should be noted that the axis of the flowmeter must be leveled, that is mean the cover is perpendicular to the horizontal. For the measurement of ultra-small flow, the best installation is down-in, up-and-out. Showed as below. (Figure 3)
- c. Requirements for liquid flow direction: The arrow pointing on the flowmeter shell should be in accordance with the direction of liquid flow in the installed pipeline.
- d. Installation requirements for special liquids (easy to crystallize and solidify liquids)
- e. Installation requirements for special liquids (easy to crystallize and solidify liquids)
- f. It is recommended that the pipe sections before and after the flowmeter be long enough and take corresponding measures to avoid liquid crystallization of the pipe section where the flowmeter is located
- g. When starting or stopping, the valve should be opened slowly to prevent sudden impact.
- h. Backflow should be prevented in order to prevent false pulses.
- y. If the liquids is easy to crystallize, please take measures to avoid liquid crystallization in the section where the flowmeter is located.



7. M series oval gear flowmeter



7.1. M series Parameter

Item	K coefficient	flow range	Connection size	Shell material	Gear material (optional)
CX-M2.1	0.055mL/p	1-200 ml/min	G1/8	SS/AL	PPS
CX-M5.2	0.11mL/p	3~300 ml/min 1~400 ml/min	G1/8	SS/AL	PPS/316L
CX-M5.1	0.25mL/p	2~800 ml/m in 5~800 ml/min	G1/8	AL	PPS/316L
CX-M6-AL	0.5mL/p	0.5~100 L/H	G1/4 or G1/8	AL	PPS
CX-M6-SS	0.5mL/p	0.5~100 L/H	G1/4 or G1/8	SS	PPS/316L
CX-M9-AL	2.5mL/p	6~600 L/H	G1/4	AL	AL/PPS/316L
CX-M9-SS	2.5mL/p	6~600 L/H	G1/4	SS	PPS/316L
CX-M12-AL	8.5mL/p	0.3~30 L/min	G1/2	AL	AL/PPS
CX-M12-SS	13.5mL/p	0.3~30 L/min	G1/2	SS	PPS/316L
CX-M25-AL	21.5mL/p	0.5~100L/min	G1	AL	AL/PPS
CX-M25-SS	33.5mL/p	0.5~100L/min	G1	SS	PPS/316L

7.2. dimension figure (MM)

Product Dimension Chart (MM)

M series aluminium (M-AL)

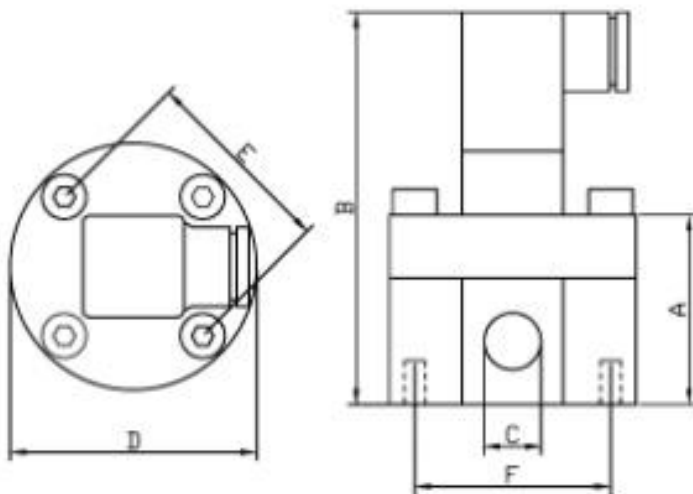

A = body thickness

B = Total height of shape

C = inlet and outlet

D = outer diameter

E = assembly screw + thread hole center distance

F = mounting screw + thread hole center distance

Item	M2.1	M5	M5.1/M6	M9	M12	M25
A	30	30	30	40	44	58
B	62	62	62	75	79	93
C	G1/8	G1/8	G1/8	G1/4	G1/2	G1
D	39	39	49	64	84	99
E	M4*31	M4*31	M4*42	M5*54	M5*70	M6*90
F	M4*31	M4*31	M4*42	M5*54	M5*72	M6*63.6

M series Stainless steel (M-SS)

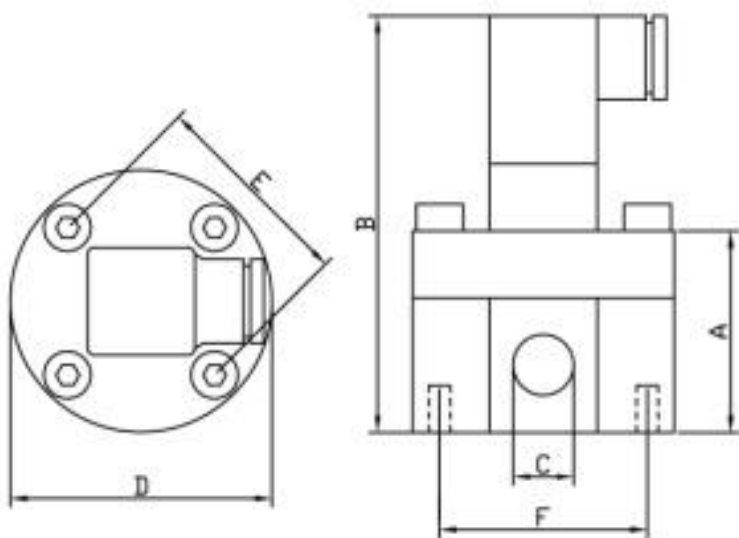

A = body thickness

B = Total height of shape

C= inlet and outlet

D = outer diameter

E=assembly screw + thread hole center distance

F=mounting screw + thread hole center distance

Item	M2.1	M5	M5.1	M6	M9	M12	M25
A	38	35	37.5	40	46.5	56	72
B	70	68	69	72	81	91	107
C	G1/8	G1/8	G1/8	G1/4	G1/4	G1/2	G1
D	39	39	49	49	64	89	113.5
E	M4*31	M4*31	M4*42	M4*42	M5*54	M5*80	M6*103
F	M4*31	M4*31	M4*42	M4*42	M5*54	M5*50	M6*60

8. G round gear flow meter



8.1G series Parameter

Item	K coefficient	flow range	Connection size	Shell material	Gear material (optional)
CX-G0.015	0.015ml/P	G1/8	0.004~0.5L/min	SS316L	SS/AL
CX-G0.025	0.025ml/P	G1/8	0.004~2L/min	SS316L	SS/AL
CX-G0.04	0.04ml/P	G1/4	0.01~4L/min	SS316L	SS/AL
CX-G0.1	0.1ml/P	G1/4	0.02~8L/min	SS316L	SS/AL
CX-G0.2	0.245ml/P	G3/8 G1/2	0.08~16L/min	SS316L	SS/AL
CX-G0.4	0.4ml/P	G1/2 G3/4	0.1~40L/min	SS316L	SS/AL
CX-G1.0	1ml/P	G1/2 G3/4	0.2~80L/min	SS316L	SS/AL
CX-G2.0	2ml/P	G1 G3/4	0.5~120L/min	SS316L	SS/AL

8.2. dimension figure (MM)

G series aluminium (M-AL)

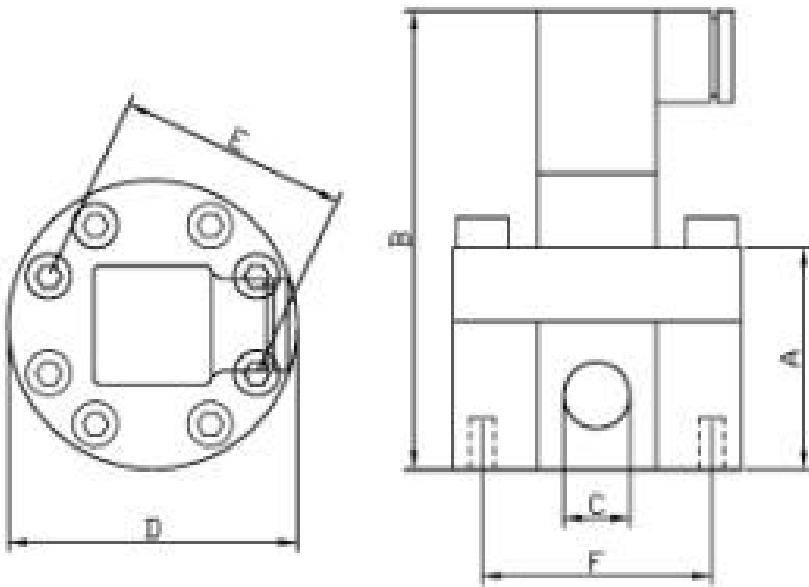

- A = body thickness
- B = Total height of shape
- C= inlet and outlet
- D = outer diameter
- E=assembly screw + thread hole center distance
- F=mounting screw + thread hole center distance

Item	G0.015	G0.025	G0.1	G0.2	G0.4	G1.0	G2.0
A	34	34	36	46	56	44	56
B	69	69	71	81	91	79	91
C	G1/8	G1/8	G1/4	G3/8	G1/2	G1/2	G3/4
D	64	64	79	79	79	99	99
E	M6*49	M6*49	M6*69	M6*69	M6*69	M6*90	M6*90
F	M5*49	M5*49	M6*69	M6*69	M6*69	M6*90	M6*90

G series aluminium (M-AL)

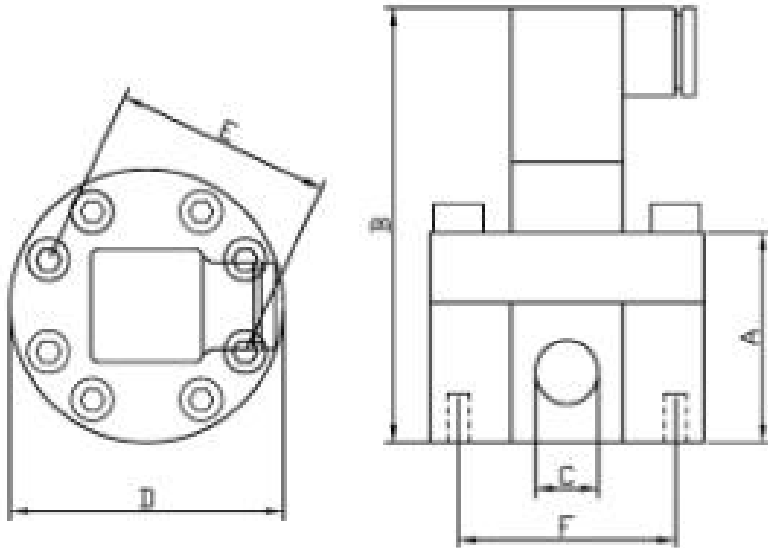

- A = body thickness
- B = Total height of shape
- C = inlet and outlet
- D = outer diameter
- E = assembly screw + thread hole center distance
- F = mounting screw + thread hole center distance

Item	G0.015	G0.025	G0.1	G0.2	G0.4	G1.0	G2.0
A	34	34	36	56	66	57	75
B	69	69	71	91	101	92	110
C	G1/8	G1/8	G1/4	G3/8	G1/2	G1/2	G3/4
D	64	64	79	79	79	99	99
E	M6*49	M6*49	M6*69	M6*69	M6*69	M6*90	M6*90
F	M5*49	M5*49	M6*69	M6*69	M6*69	M6*90	M6*90

G series High pressure aluminum

(G-AL-HP)

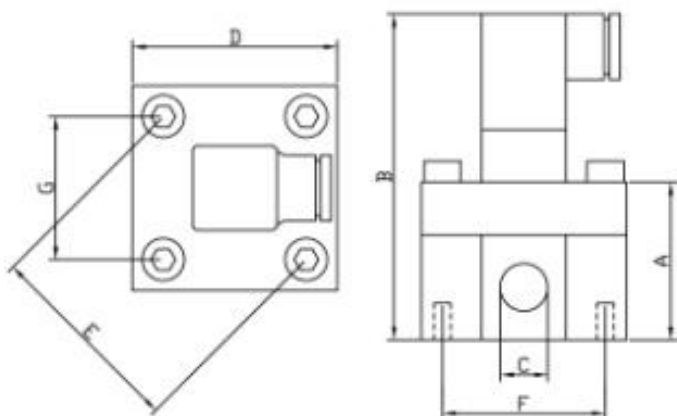

A = body thickness

B = Total height of shape

C = inlet and outlet

D = outer diameter

E = assembly screw + thread hole center distance

F = mounting screw + thread hole center distance

Item	G0.1	G0.2	G0.4	G1.0	G2.0
A	85	90	100	110	120
B	120	125	135	145	155
C	G1/4	G1/2	G3/4	G3/4	G1
D	80	80	80	100	100
E	M16*70	M16*70	M16*70	G=M18*66	G=M18*66
F	M8*49.5	M8*49.5	M8*49.5	M12*84	M12*84

G series High pressure stainless steel

(G-SS-HP)

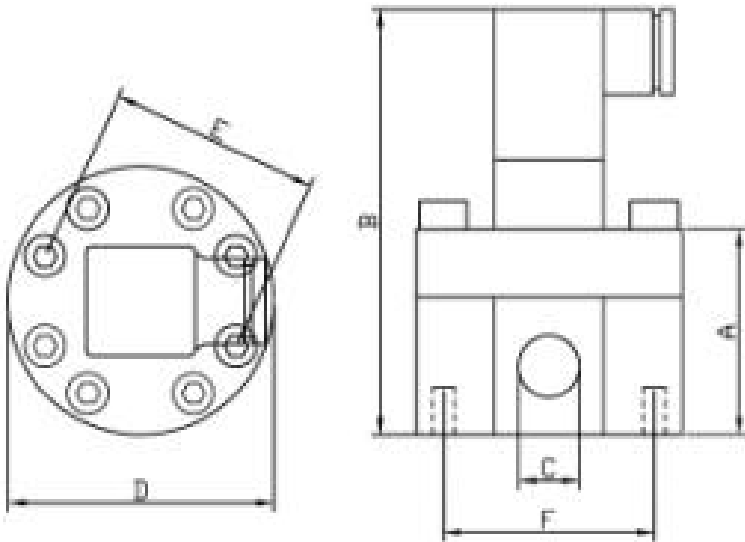

A = body thickness

B = Total height of shape

C = inlet and outlet

D = outer diameter

E = assembly screw + thread hole center distance

F = mounting screw + thread hole center distance

Item	G0.015	G0.025	G0.1	G0.2	G0.4	G1.0	G2.0
A	34	34	65	70	80	73	91
B	69	69	100	105	115	108	126
C	G1/8	G1/8	G1/4	G3/8	G1/2	G1/2	G3/4
D	64	64	89	89	89	99	99
E	M6*49	M6*49	M10*75	M10*75	M10*75	M6*90	M6*90
F	M5*49	M5*49	M10*75	M10*75	M10*75	M6*90	M6*90

9. P series Plastic gear flow meter

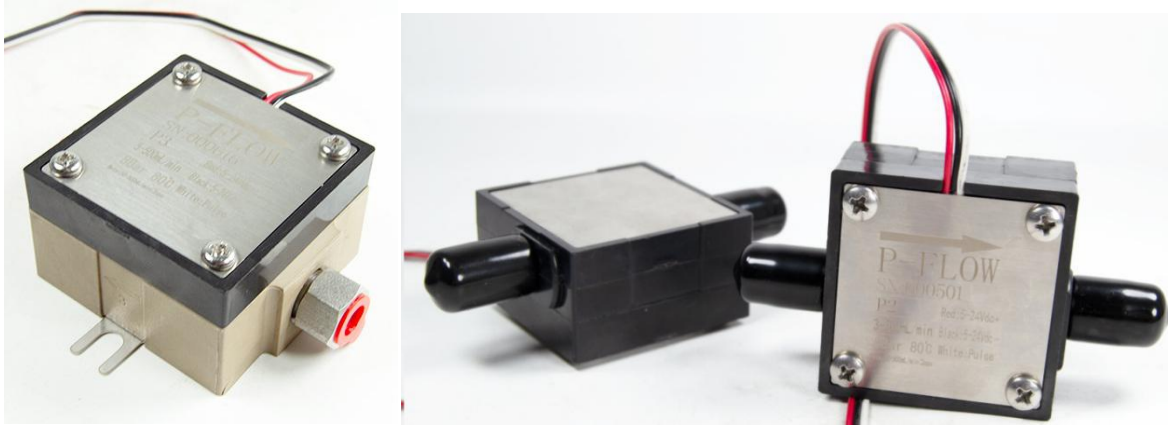

9.1 P series Parameter

Item	K coefficient	flow range	Connection size	Shell material	Gear material
CX-P1	0.055 ml/p	1-100 ml/min	1/4BSP	PPS	PPS
CX-P2	0.175 ml/p	3-300 ml/min	1/4BSP	PPS	PPS
CX-P3	0.25 ml/p	5-500 ml/min	1/4BSP	PPS	PPS
CX-P4	0.5 ml/p	10-1000ml/min	1/2BSP	PPS	PPS
CX-P5	2.5 ml/p	50-5000ml/min	1/2BSP	PPS	PPS

9.2 PS series Parameter

Item	K coefficient	flow range	Connection size	Shell material	Gear material
CX-PS1	0.055 ml/p	1-100 ml/min	1/4BSP	PPS+SS	PPS
CX-PS2	0.175 ml/p	3-300 ml/min	1/4BSP	PPS+SS	PPS
CX-PS3	0.25 ml/p	5-500 ml/min	1/4BSP	PPS+SS	PPS
CX-PS4	0.5 ml/p	10-1000ml/min	1/2BSP	PPS+SS	PPS
CX-PS5	2.5 ml/p	50-5000ml/min	1/2BSP	PPS+SS	PPS

9.2. dimension figure (MM)

P/PS series outline drawing

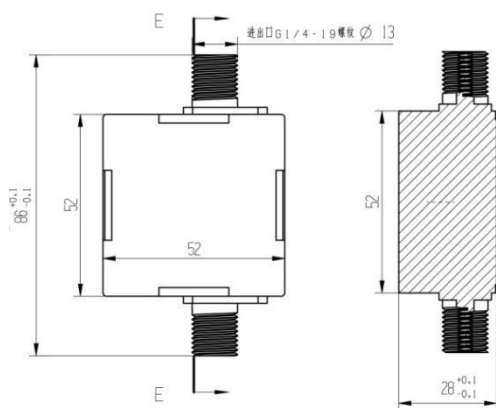

P1/P2(PS1/PS2)

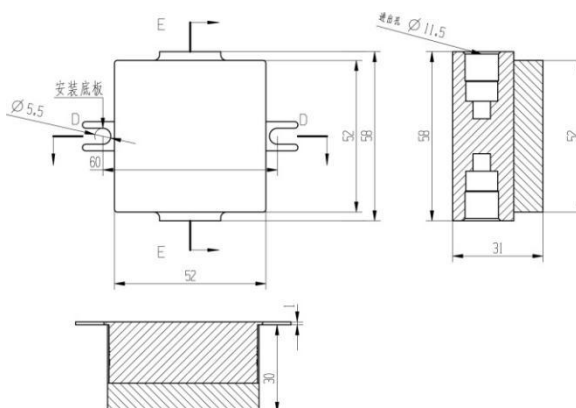

P3/ PS3

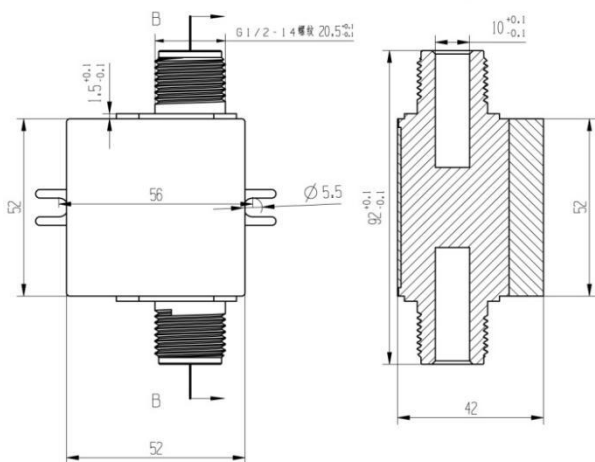

P4/PS4

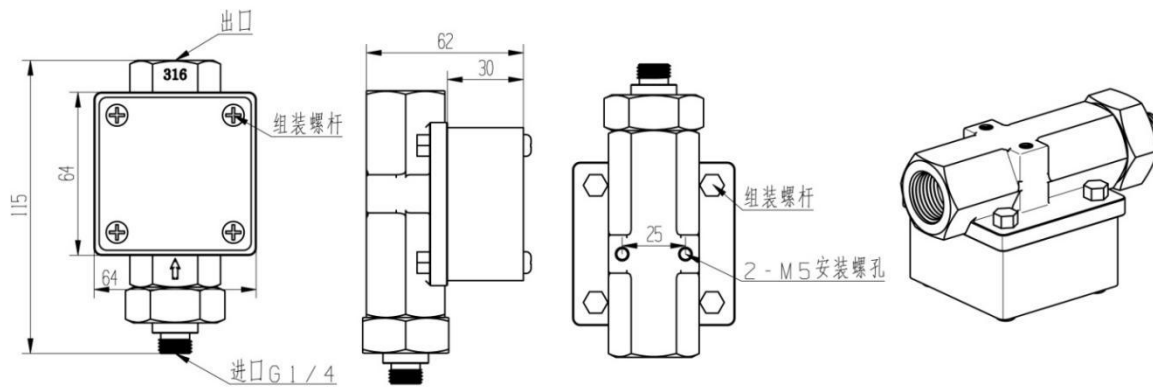

P5/PS5



10. Selection list

CX		CODE	REFERENCE
series	M		M2.1、M3、M5.2、M5.1、M6、M9、M12、M25
	G		G0.015、G0.025、G0.04、G0.1、G0.2、G0.4、G1.0、G2.0
	P		P1、P2、P3、P4
	PS		PS1、PS2、PS3、PS4
Body material	AL		Aluminum
	SS		Stainless steel
	P		PPS
	PS		PPS+Cast stainless steel
Pressure	N		Normal pressure
	HP		High pressure
	HT		High temperature
	HTP		High pressure and high temperature
Gear material	A		aluminum
	P		PPS
	S		Stainless steel
Axle material	TZ		ceramic
	SZ(H)		stainless(black)
	SZ(B)		stainless(white)
	SZC		Stainless bearing
	TZC		Ceramic bearing
Anti-hazard classification	N		Without anti-explosion
	B		DII BT4 anti-explosion

Note: Special requirements such as high temperature, high pressure, high frequency, bidirectional measurement, special materials can be customized.

Power supply: 5-26VDC

Accuracy: 0.5%, 0.2%

Temperature: - 40 - 80 degrees (High Temperature Customization, pls Consult Engineer)

Pressure: 32BAR (High Voltage Customization, pls Consult Engineer)

Signal: square wave pulse, split display and output: current, RS485, RS232 Modbus



Example

CX-M2.1-SS-NP-P-TZ

Micro oval gear flow meter

Accuracy :0.5%

Temperature:-30-80°C

Flow range:1-200ml/min

Body material:SS316

Pressure :32bar

Gear :PPS ceramic axle

connection:G1/8

output:square wave pulse (hall)

Power supply:4-26VDC

11. Application industry

Working conditions: gear lubrication, fuel consumption monitoring, robot dispensing, electrostatic spraying, fuel injection testing, hydraulic leaking, deep water sampling, injector test bench, hydraulic pump test bench, drone, hot melt dispensing, dual component , Freon measurement, chip cutting, water treatment system, odorizing system, polyurethane foaming machine, twin-screw extruder, transformer oil leakage, alcohol heating, glue mixing, etc. It is used to measure various high and low viscosity liquids such as grease, resin, lubricating oil, odorant, brake fluid, coolant, perfume, and volume.

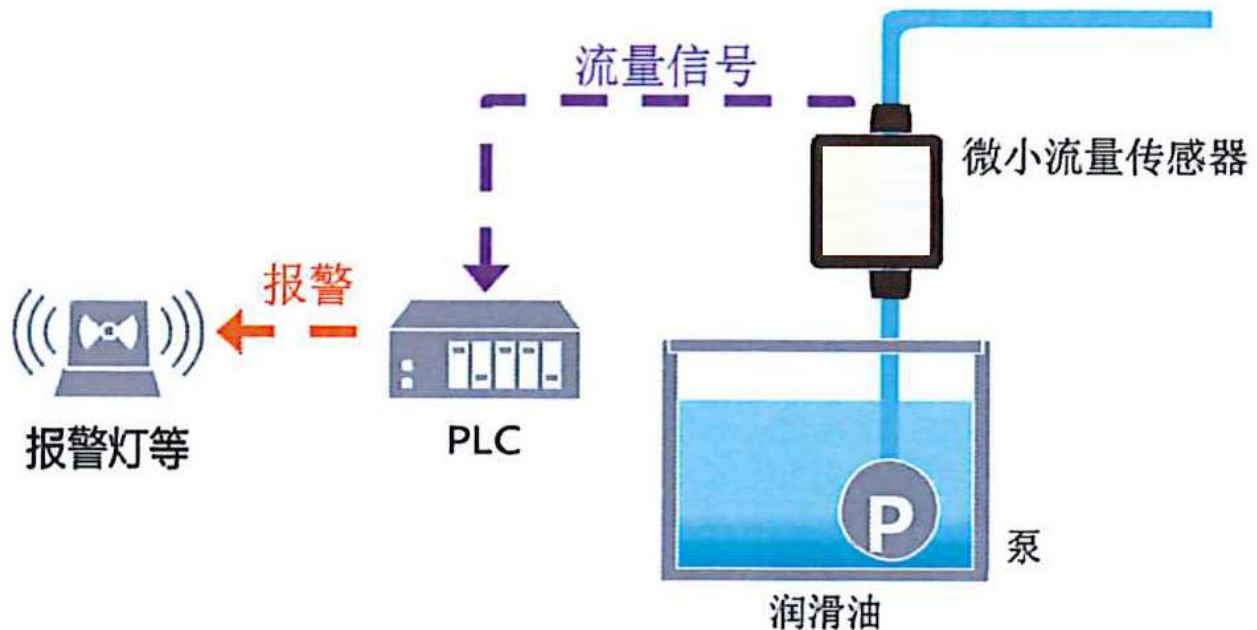

11.1 Application industry illustrate

Industry 1. flow meter for dispensing and coating glue

Medium: Silicon glue, Epoxy resin, Glass glue, One-component glue, Polyurethane, UV glue, Anaerobic adhesive, Water-based glue, Battery glue, Polyurethane glue, Sealing glue, dispensing, Two-component glue, White latex, Latex, Hydrosol.

Function: dispense/gumming

Suitable model: G series/High temperature optical fiber

Industry 2. Flow meter for reactant injection in reactor

Medium: Tetra Fluoro Thiophene, chemical solvents, caprolactam, polymethylene polyphenyl isocyanate, acetonitrile, Pyridines, potassium ketone peroxide, chemical reagents, tetrahydrothiophene, etc.

Function: Reactor flow monitoring

Suitable model: M series/P series M2.1、M5.2、M5.1、P1、P3、P4

Industry 3. Flow meter for high-pressure foaming machine



Medium : Polyurethane (polyurethane sole material, polyurethane synthetic leather, polyurethane fiber)

Function : Accurate control of double group distribution ratio

Suitable model: G series/High voltage board mounted photos G0.04、 G1.0、 G2.0

Industrial 4.Flow meter for fuel injection nozzle test bench

Medium : Fuel, gasoline, diesel

Function: Nozzle regulated flow test (oil measurement method)

Suitable model: M5.1、 M5.2

Industry 5.Flow meter for equipment point lubrication system

Medium : Grease

Function : Grease or lubricating oil can be added precisely in the required amount

Suitable : G series/M series

Industry 6.Flow meter for desulfurization and denitrification

Medium : ammonia

Function : Grease or lubricating oil can be added precisely in the required amount

Suitable : G series/M series

12. Troubleshooting guide

Fault phenomenon	reason	Failure and elimination
Gear does not rotate	a) Foreign matter is blocked, the gear is stuck by debris b) Pipeline filter blockage c) damaged rotor, gear shaft deformation d) The flow meter connector is screwed tightly, causing the cavity to deform e) liquid curing	a) Remove the instrument, clean the rotor, the pipe must be fitted with a filter b) cleaning filter c) Replace the gear, the pipe must be fitted with a filter d) re-adjust the connection e) Prevent liquid solidification, heat cleaning or disassembly cleaning
Smaller flow (resistance)	a) Partially blocked filter b) the liquid is too sticky	a) cleaning filter b) Do not exceed the flowmeter



becomes larger)		specified viscosity
Flow error is too large	a) The actual use flow range is lower or larger than the available range b) air in the liquid c) excessive flow causes excessive wear d) The flow meter is installed in the wrong direction e) Impurity blocking gear	a) Do not overuse b) avoid air in the pipeline c) The correct option, you need to select the flow meter corresponding to the range d) the best position to go up and down; e) need cleaning
Instrument without pulse signal	a) Circuit failure b) the gear is stuck c) The circuit is connected incorrectly or the circuit is destroyed d) The host computer and the pulse signal do not match	c) replace the circuit b) need to clean gears and cavities c) Reconnect the circuit correctly or replace the circuit. d) Select a matching upper computer

13. Precautions for use:

- a. When starting or stopping, the opening and closing valve should be slow to prevent sudden impact.
- b. To prevent false pulses, reverse flow should be prevented.
- c. Always install a filter on the front of the flowmeter.
- d. If it is a liquid crystal, please take measures to avoid liquid crystallization of the pipe section where the flowmeter is located.

14. Warranty date

According to the provisions of the maintenance manual, the company guarantees normal operation within one year under the correct use and storage. If the damage occurs due to poor manufacturing quality or does not work properly during the specified time, our company will guarantee the user, warranty, return, and exchange.

Our company does not guarantee the pump that is disassembled and repaired without authorization.



SHANGHAI CI INSTRUMENT CO., LTD

SELECTION MANUAL

Our company does not pay any responsibility for the direct or indirect losses caused by the user's failure to follow the instructions.

Except for the above contents, the relevant explanations and regulations shall be implemented in accordance with the document of the State Economic and Trade (1995) No. 485 (Responsibility for the Repair, Replacement, and Restitution of Some Commodities).