

Standard Performance

Accuracy rating: $\pm 0.1\%$ of span (aside from the $\pm 0.1\%$ accuracy of the external resistor on current-input models); accuracy is not guaranteed for output level less than 0.5% of the span of a 0 to X mA output range type.

Selection sensitivity: 0.5% of span

Response: 150 ms for a 63% response (10 to 90% change of range)

Insulation resistance: 100 M Ω minimum at 500 V DC between input, output-1, output-2, power supply and grounding terminals mutually

Withstanding voltage: 2000 V AC for one minute between input, (output-1, output-2), power supply and grounding terminals mutually;

1000 V AC for one minute between output-1 and output-2 terminals

Operating temperature range: 0 to 50°C

Operating humidity range: 5 to 90% RH (no condensation)

Supply voltage range: 100-240 V AC/DC \approx (-15, +10%) 50/60 Hz or 15-30 V DC \approx ($\pm 20\%$)

Effects of power line regulation: Up to $\pm 0.1\%$ of span for a supply voltage range of 85 to 264 V AC (47 to 63 Hz), 85 to 264 V DC or 12 to 36 V DC

Effects of ambient temperature variations: Up to $\pm 0.2\%$ of span per 10°C

Power Dissipation: 24 V DC 2.3 W, 10 V DC 2.2 W
100 V AC 4.6 VA, 200 V AC 6.4 VA

Mounting and Appearance

Material: ABS resin (casing)

Mounting: Wall mounting, DIN rail mounting, or mounting on a side-by-side multiple mounting base

Connection: Terminals with M3 size screws

External dimensions: 76 (H) \times 29.5 (W) \times 124.5 (D) mm

Weight: Main unit = approx. 120 g; socket = approx. 51 g

Accessories

Tag number label: One

Resistor module: Two (for current input model)

Customized Signal Specifications

Table 1 Manufacturable Ranges

	Current Signal	Voltage Signal
Output range	0 to 24 mA DC	-10 to +10 V DC
Span	1 to 24 mA DC	10 mV to 20 V DC
Zero elevation	0 to 200%	-100% to +200%

Terminal Assignments

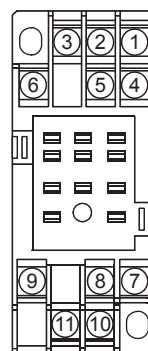

1	INPUT 1	(+)
2	OUTPUT 2	(+)
3	INPUT 1	(-)
4	INPUT 2	(+)
5	OUTPUT 2	(-)
6	INPUT 2	(-)
7	OUTPUT 1	(+)
8	GND	
9	OUTPUT 1	(-)
10	SUPPLY	(L+)
11	SUPPLY	(N-)

Note: For single-output models, OUTPUT2 is N.C.
Do not use N.C. terminal

F02.ai

Block Diagram

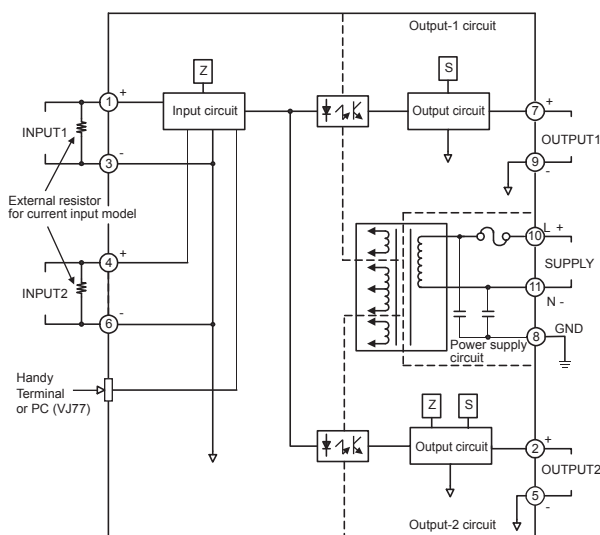

Note: Single-output models do not contain the output-2 circuit.

F03.ai

External Dimensions

