

VIEW A-A (2 : 3)

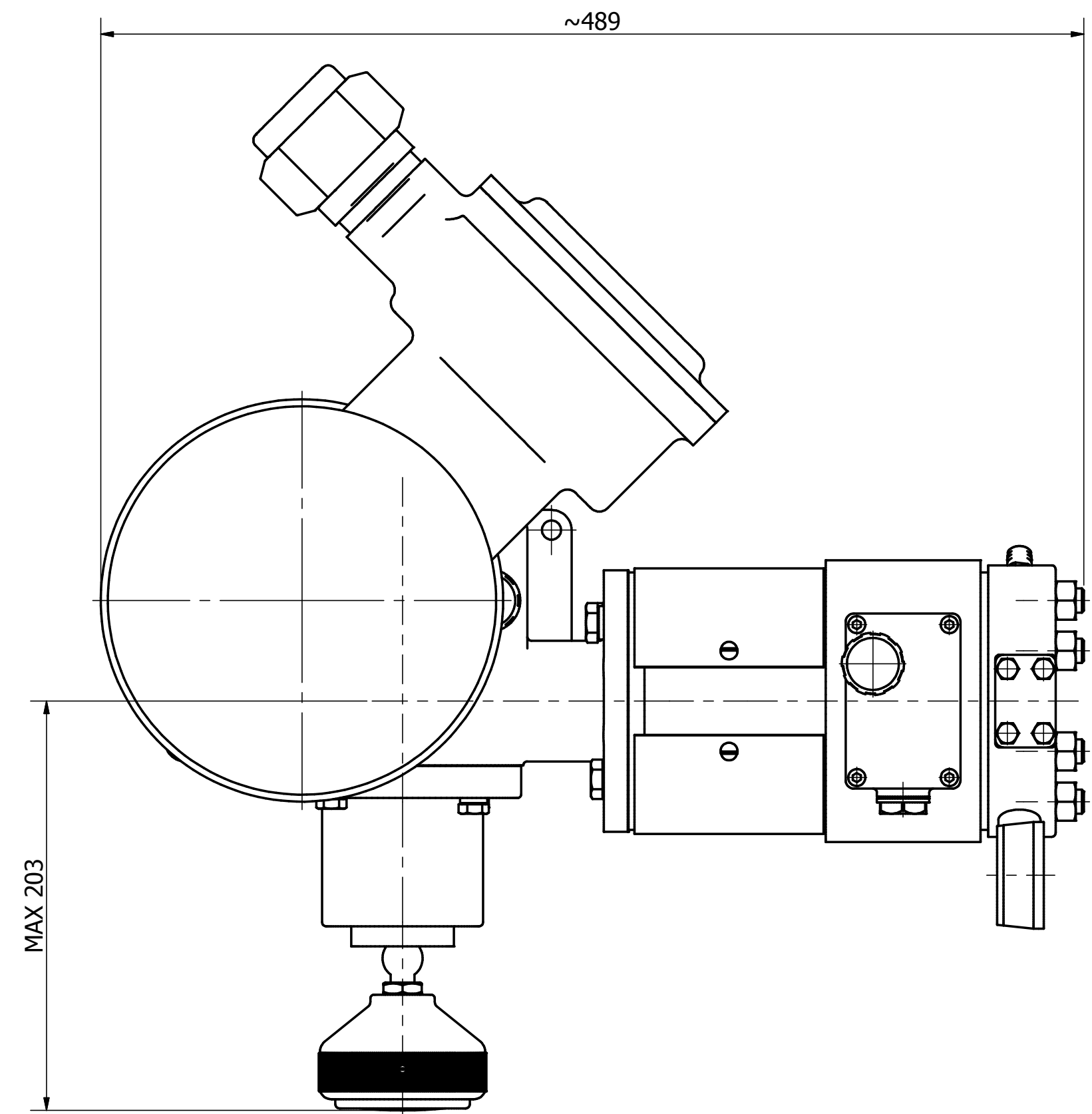

MOTOR	DRY WEIGHT [KG]		OIL [LITER]	
	SAFE	EXD	PUMP HEAD	GEAR
	-	~34		
PUMP, Ø16 mm	~38		0.25	0.25
MACHINE	-	~72		

1. UNLESS OTHERWISE SPECIFIED ALL DIMENSIONS ARE IN MILLIMETERS.
2. DIMENSIONS ENCLOSED WITHIN PARENTHESES INDICATE REFERENCE.
3. REFER YOUR INSTALLATION MANUAL FOR RECOMMENDED OIL QUALITY.

NOTE:

CASTING NUMBER	-	Projektion ISO 128 - 30	DISCLAIMER
INVENTOR MODEL	-	Projection ISO 128 - 30	SPXFLOW RESERVES THE RIGHT TO ALLOW FOR MINOR DEVIATIONS FROM DIMENSIONS STATED BASED ON MOTOR SELECTION.
DESIGNED	-		

Bran+Luebbe TITLE 1 METERING PUMP
TITLE 2 K PUMP

DRAWN	PSR	10/05/17	MATERIAL	-	IDENT-NO.	-	REV	0
CHECKED	PSR	10/05/17	FORMAT	A1	SCALE	1 : 2.5	SHEET	1 / 1
APPROVED	T RIEL	15/05/17	DRAWING-NO.	GA-K-16-M-G-NPT				
RELEASED	T RIEL	15/05/17						

- INVENTOR-DRAWING -
 This drawing is copyrighted by SPXFLOW and is being transmitted to the recipient, who by receiving it, acknowledges that SPXFLOW owns the copyright in the drawing, and agrees not to distribute or make public the drawing in whole or in part to any third parties, copy or reproduce the drawing in whole or in part except to the extent necessary pursuant to a written agreement between SPXFLOW and the recipient. Recipient also agrees to return or destroy any copies of this drawing upon request by SPXFLOW.