

# WK SERIES

## 2-wire TRANSMITTER



**Monitors or signal converters are unnecessary.**

**Electric current output makes long wiring possible.**

**Direct connection to control instruments.**

**The ideal system for monitoring small compressor vibrations.**

**Sales**  
**SHINKAWA Electric Co., Ltd.**

3rd Fl. Shin-kojimachi Bldg.3-3 Kojimachi 4-chome, Chiyoda-ku, Tokyo 102-0083, Japan  
 Tel : +81-3-3263-4417 Fax : +81-3-3262-2171 E-mail : InternationalSalesEU@shinkawa.co.jp  
 Web : <https://www.shinkawa.co.jp/eng/>

**Manufacturing**  
**SHINKAWA Sensor Technology, Inc.**

4-22 Yoshikawa-kogyodanchi, Higashihiroshima, Hiroshima 739-0153, Japan  
 Tel : +81-82-429-1118 Fax : +81-82-429-0804 E-mail : info@sst.shinkawa.co.jp  
 Web : <https://www.shinkawa.co.jp/sst/>

\* Specifications, outline drawings and other written information can be changed without notice.  
 \* When exporting Shinkawa products, permission may be required for export or service transactions, pursuant to the provision of the Foreign Exchange and Foreign Trade Act.  
 When re-exporting Shinkawa products, permission may be required from the US Department of Commerce, pursuant to the provision of the Export Administration Regulation (EAR).  
 Please contact our service representatives for further information.

Published in Feb.2023

# SIMPLE WIRING - 2-WIRE TRANSMITTER

The WK series transmitter is an eddy-current type transmitter that incorporates vibration converter features, supplying the power and transmitting the signal with a 2-wire current loop. The WK system reduces equipment and wiring costs. Two kinds of transmitters are available - the WK-142K for shaft vibration, and the WK-142T for thrust position.

**Monitors or vibration converters are unnecessary.**  
**Electric current output makes long wiring possible.**  
**Direct connection to control instruments.**  
**The ideal system for monitoring small compressor vibrations.**



CE compliance

## Example of SYSTEM CONFIGURATION

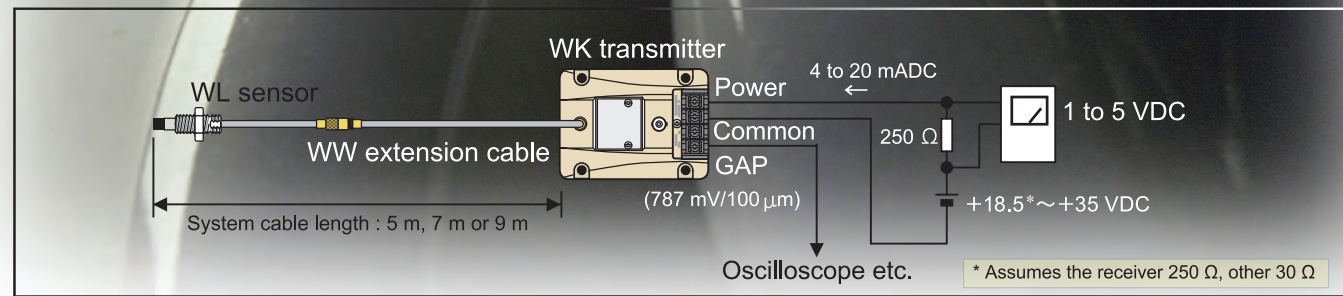

## Outline Drawing

### WK Transmitter

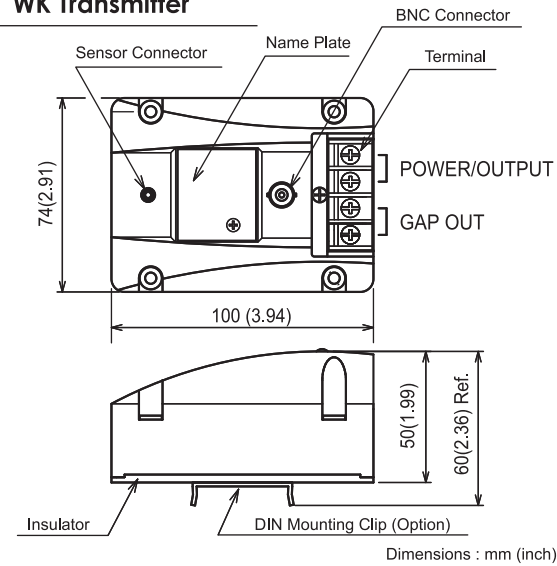

## Specifications

	WK-142K	WK-142T
<b>Current Output</b>	<b>4 to 20mA Output Range</b> 0 to 100 μm pk-pk, 0 to 125 μm pk-pk, 0 to 200 μm pk-pk, 0 to 250 μm pk-pk, 0 to 400 μm pk-pk	-0.6 to 0 to +0.6 mm, -0.635 to 0 to +0.635 mm (-25 mils to 0 to +25 mils)
<b>4 to 20mA Output Conversion Accuracy</b>	± 1.5% of full scale range (from test signal input pin to current output)	± 1.0% of full scale range (from test signal input pin to current output)
<b>Max. Load Resistance</b>	43.5 × (Vps-12) Ω (Vps=Power supply voltage)	
<b>Calibration Material</b>	JIS SCM440 flat (AISI 4140 equivalent)	
<b>Gap Output</b>	<b>Linear Range*</b> 1.4 mm (Gap : 0.3 to 1.7 mm)	
<b>Scale Factor*</b>	7.87 mV/μm	
<b>Scale Factor Error*</b>	7.87mV/μm±6.5% typ. (including interchangeability errors) Step : 200μm, Target : 30 mm dia.	
<b>Output Impedance*</b>	10 kΩ (it is calibrated load impedance at 10 MΩ)	
<b>Frequency Response*</b>	5 Hz to 6,000 Hz (+0 dB, -3 dB) at 900 μm Gap	
<b>System</b>	<b>Operating Temperature Range</b> Transmitter : 0 to 70°C Sensor & Extension cable : -34 to +177°C (Connector : Max.125°C)	
<b>Relative Humidity</b>	95% RH (non-condensing)	
<b>Power Supply Voltage</b>	12 to 35 VDC	
<b>System Cable Length</b>	5 m, 7 m or 9 m	5 m, 7 m

\* The above specifications apply at 25°C with 24 VDC power supply and SCM440 (AISI 4140 equivalent) steel flat target.

## Model Code

### For Shaft Vibration

WK-142K □ - □ /NB □ /DNC

System Cable Length	Output Range	Non-incendive	With DIN Mounting Clips
1 5 m	1 0 to 100 μm pk-pk	1 CSA : Class I Div.2 Gr. A,B,C,D ATEX : Ex nA II T4 Gc	
2 7 m	2 0 to 125 μm pk-pk	8 KTL : Ex nA II T4	
5 9 m	3 0 to 200 μm pk-pk	C TR-CU : 2Ex nA II T4 Gc X	
	4 0 to 250 μm pk-pk		
	5 0 to 400 μm pk-pk		

### For Thrust Position

WK-142T □ - □ /NB □ /DNC

System Cable Length	Output Range	Non-incendive	With DIN Mounting Clips
1 5m	1 -0.6 to 0 to +0.6 mm	1 CSA : Class I Div.2 Gr. A,B,C,D ATEX : Ex nA II T4 Gc	
2 7m	2 -0.635 to 0 to +0.635 mm (-25 to 0 to +25 mils)	8 KTL : Ex nA II T4	
		C TR-CU : 2Ex nA II T4 Gc X	

## Outline Drawing and Model Code

### WL Sensor

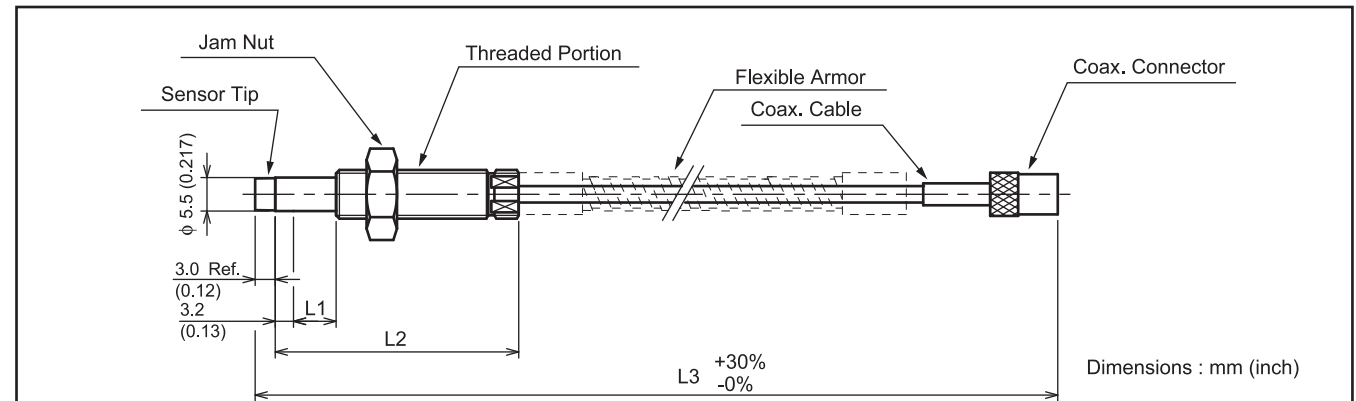

WL-142K05 □ - □ □ □ □ □ □ /NB □

	Armor	Threaded Size	Unthreaded length* (L1)	Case length* (L2)	Cable length (L3)	Non-incendive
A	With (Without Fluoro resin coating)	M1	M8 x 1	10 mm step, 0 to 230 mm e.g.) 06 = 60 mm L1 ≤ L2 - 20 mm	10 mm step, 20 to 250mm e.g.) 25 = 250 mm	1 CSA : Class I Div2 GR. A,B,C,D ATEX : Ex nA II T4 Gc
		M2	M10 x 1			8 KTL : Ex nA II T4
T	With (With Fluoro resin coating)	U1	1/4-28 UNF-2A	0.1 inch step, 0 to 9.2 inch e.g.) 04 = 0.4 inch L1 ≤ L2 - 0.7 inch	0.1 inch step, 0.8 to 9.9 inch e.g.) 35 = 3.5 inch	C TR-CU : 2Ex nA II T4 Gc X
		U2	3/8-24 UNF-2A			
L	Without					

\* inch for UNF-2A thread  
mm for M thread

### WW Extension Cable

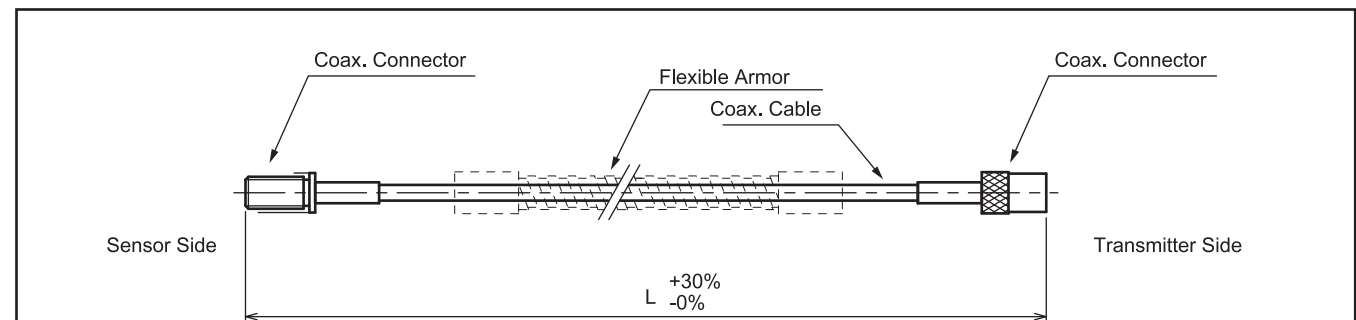

WW-142K □ - □ /NB □

	Armor	Extension Cable length	Non-incendive
A	With (Without Fluoro resin coating)	1 4.0 m	1 CSA : Class I Div.2 Gr. A,B,C,D ATEX : Ex nA II T4 Gc
T	With (With Fluoro resin coating)	2 4.5 m	8 KTL : Ex nA II T4
L	Without	3 6.0 m	C TR-CU : 2Ex nA II T4 Gc X
		4 6.5 m	
		5 8.0 m	
		6 8.5 m	